

The new
RF & High-Speed
Acquisition
Systems
for High-Gradient Tests

Raquel Fandos Marín

Outline

- The purpose of an RF Acquisition System
- The Existing System:
 - Currently Monitored Signals
 - Existing Electronic System Scheme
- Why do we want a New System?
- New Signals for the New System
- Next Configuration of the System
- Status
 - What has been already done
 - What will be ready for the beginning and for the middle of the run

The Purpose of our RF Acquisition System

- Most basic **DIAGNOSTIC** for our RF structures in different parts of the system:
 - Field/power levels
 - Pulse length/shape
- For **CONDITIONING**. We want to be able to detect a breakdown and stop the machine. Mechanisms:
 - Faraday Cup threshold
 - Vacuum levels
 - Missing energy detection

The Currently Monitored RF and Diagnostics Signals

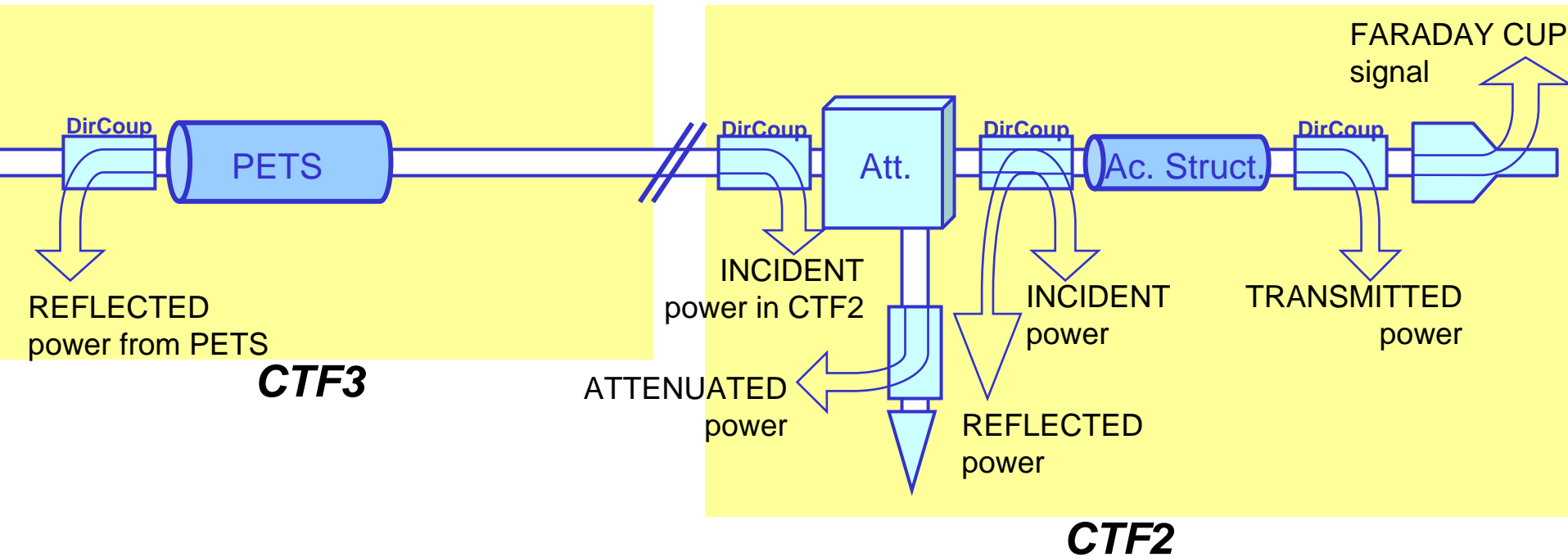

- **SIGNALS:**
 - 6 30GHz RF Signals
 - 1 Faraday Cup Signal

The Existing Electronics Scheme

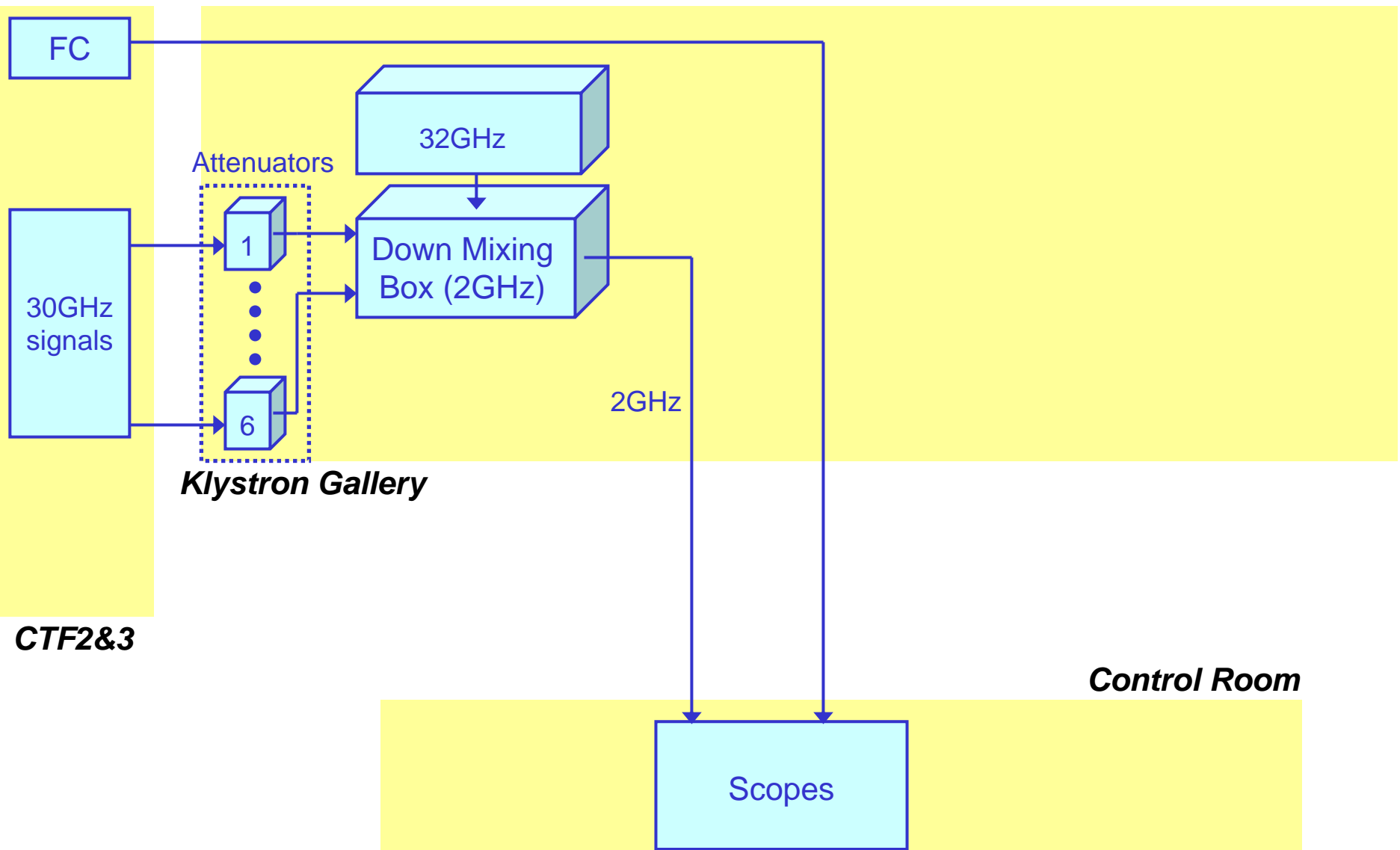

Why do we want a new system?

1. To make AUTOMATIC CONDITIONING
2. To be able to STORE the data and PROCESS it efficiently
3. To have a LARGER NUMBER of analyzed signals

First approach already done in last run:

LabView program processing data captured by the scopes.

Improvements:

Much more EFFICIENT PROCESSING of the data

Problems:

- Incapability of Real Time processing → impossible RT calculation of missing energy (desirable for conditioning)
- Instability of Windows → Unreliable for automatic conditioning

Solution:

Digitizer Cards, C program over Linux. More ROBUST, FASTER.

Moreover:

Modular system → more signals to be added in longer term.

Signals of Interest in the New System

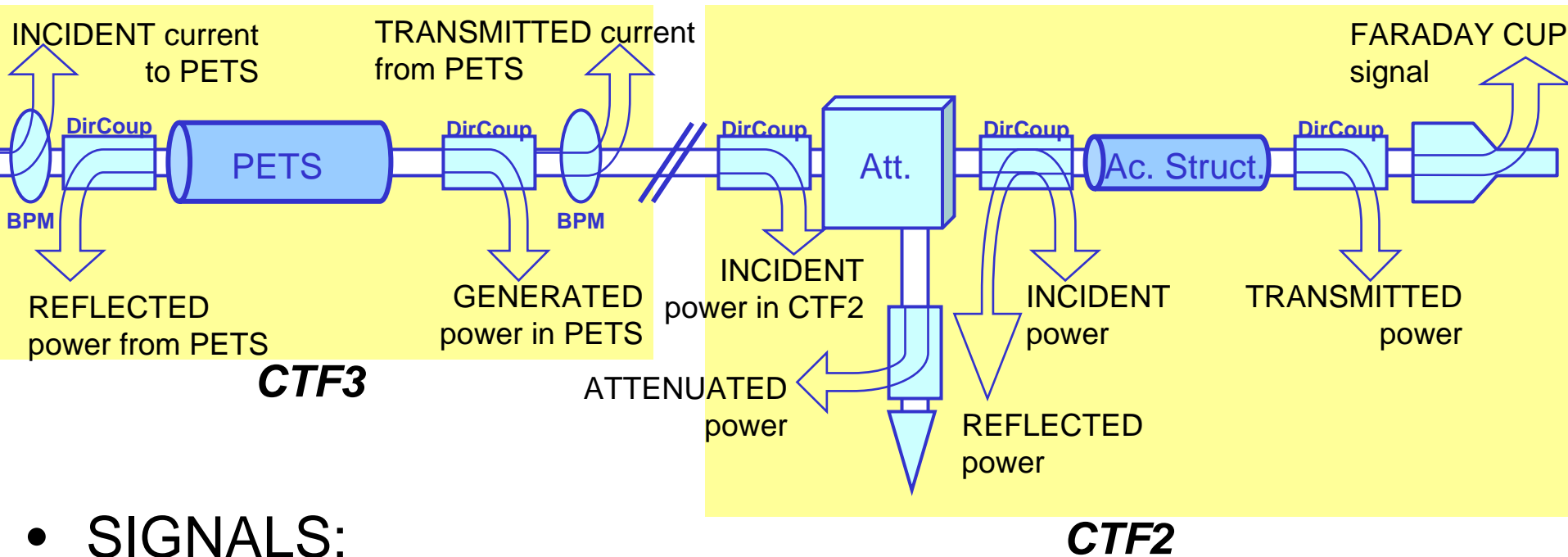

- **SIGNALS:**

- 6 30GHz RF Signals
- 1 Faraday Cup Signal

- **NEW SIGNALS:**

- 1 new 30GHz RF Signal
- 2 Signals from 2 BPM

- **POSSIBLE FUTURE SIGNALS:**

- 2-Beam Test Stand Signals
- Acoustic Sensors Signals
- Vacuum Level Signals

The New Electronics Scheme: Next Configuration

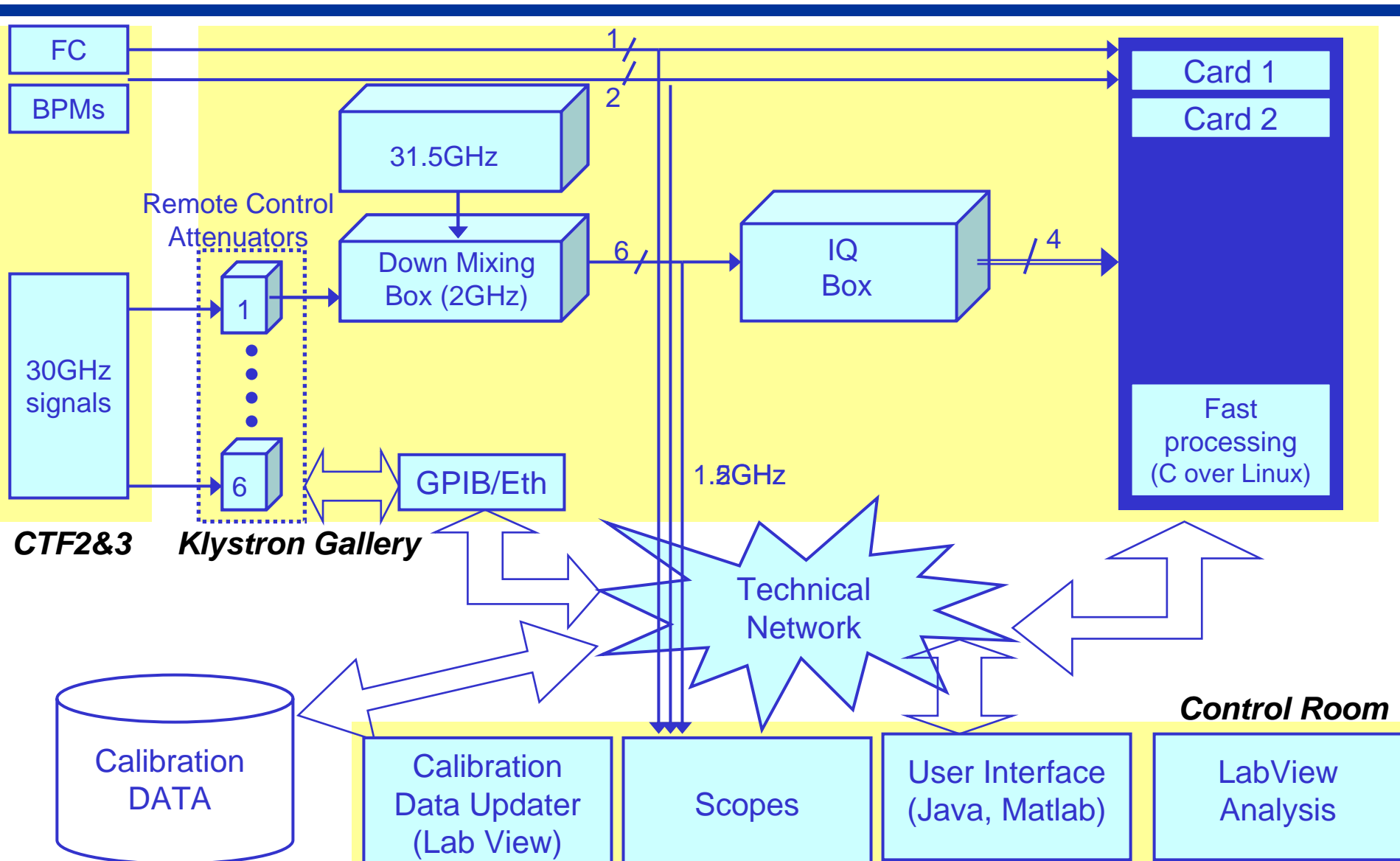

Status

- What we already have: HARDWARE
 - 6 Programmable attenuators (tested and calibrated)
 - 1 Down mixing box and 1 IQ box (tested)
 - The 31.5GHz generating box (by Jonathan Sladen)
 - 2 Digitizer Cards (8 channels → 2 RF channels + 2BPM signals + FC)

The programmable attenuators



The programmable attenuators



Attenuation at 29.9855GHz

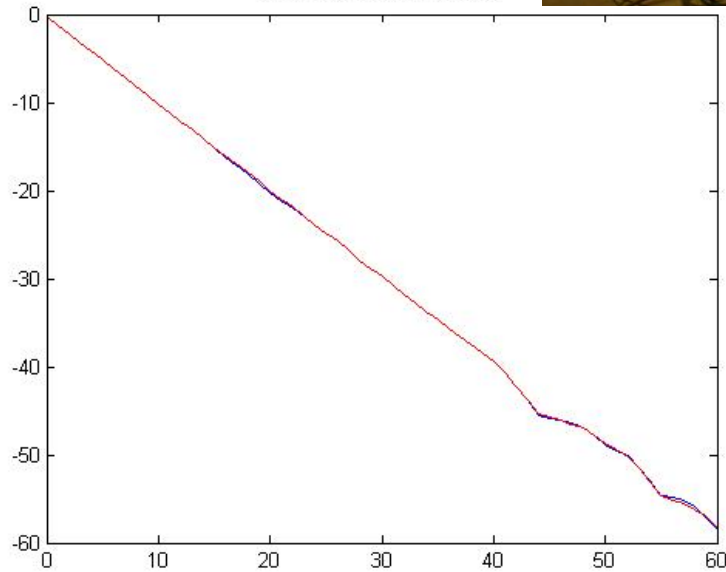

ATTENUATION

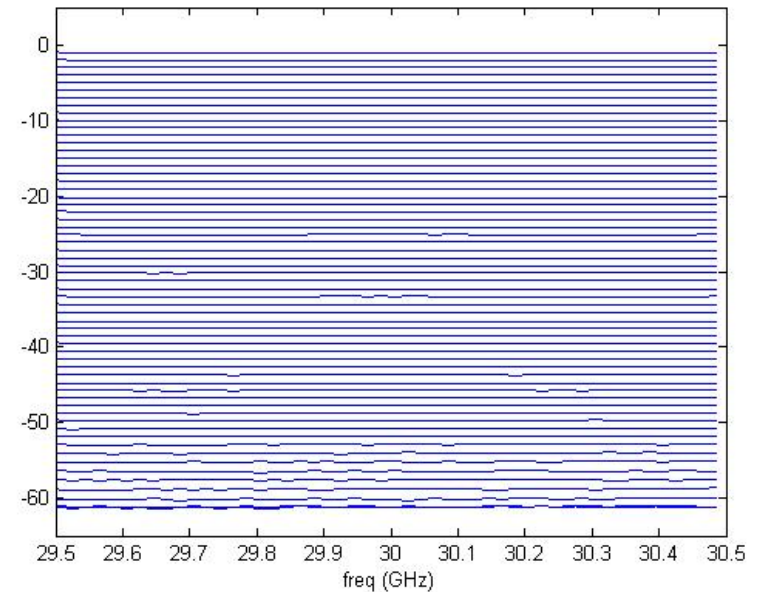

The Down Mixing Box

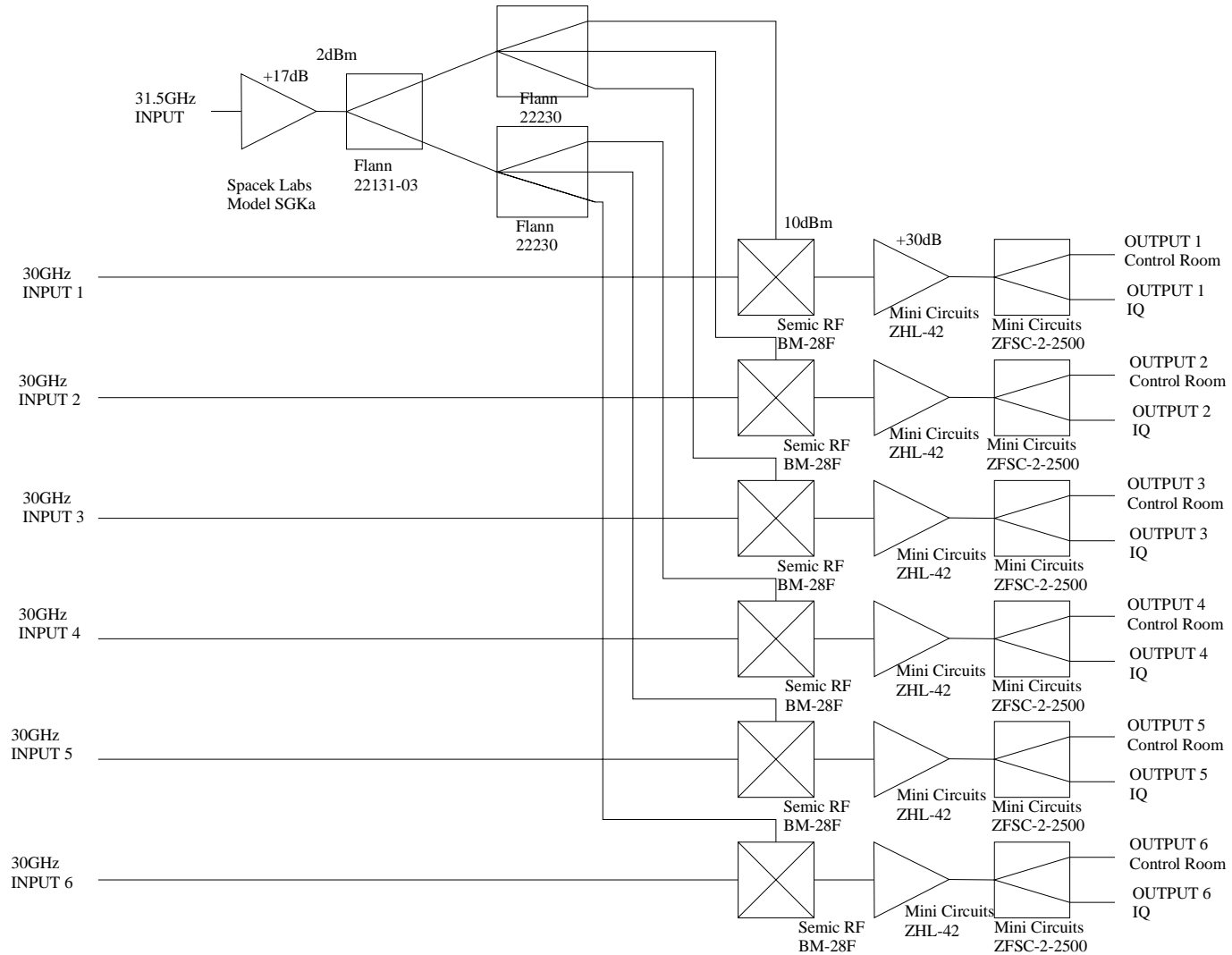

The Down Mixing Box



The Down Mixing Box: Testing

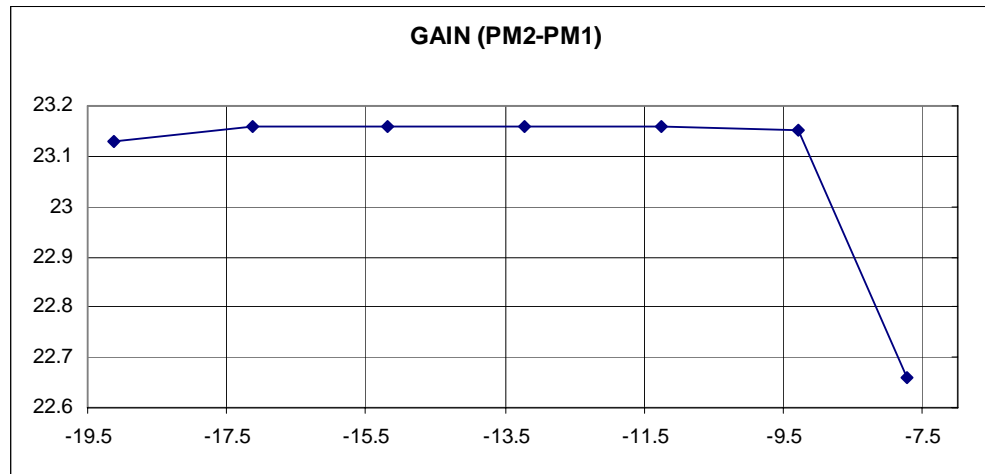
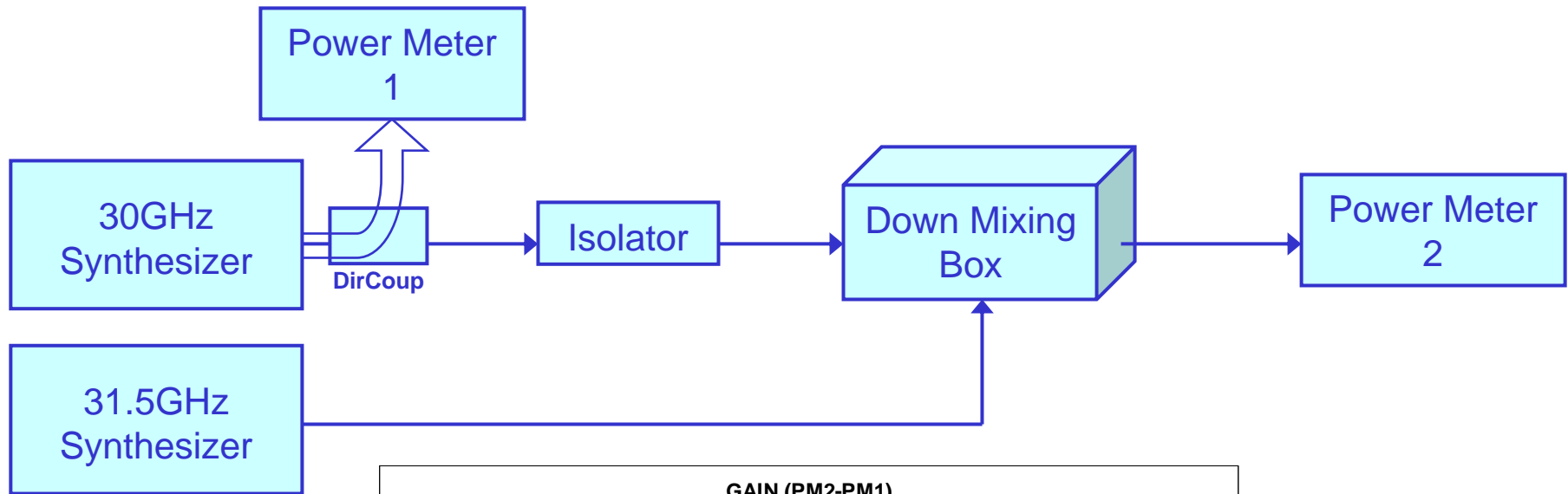

The 31.5GHz Generating Box

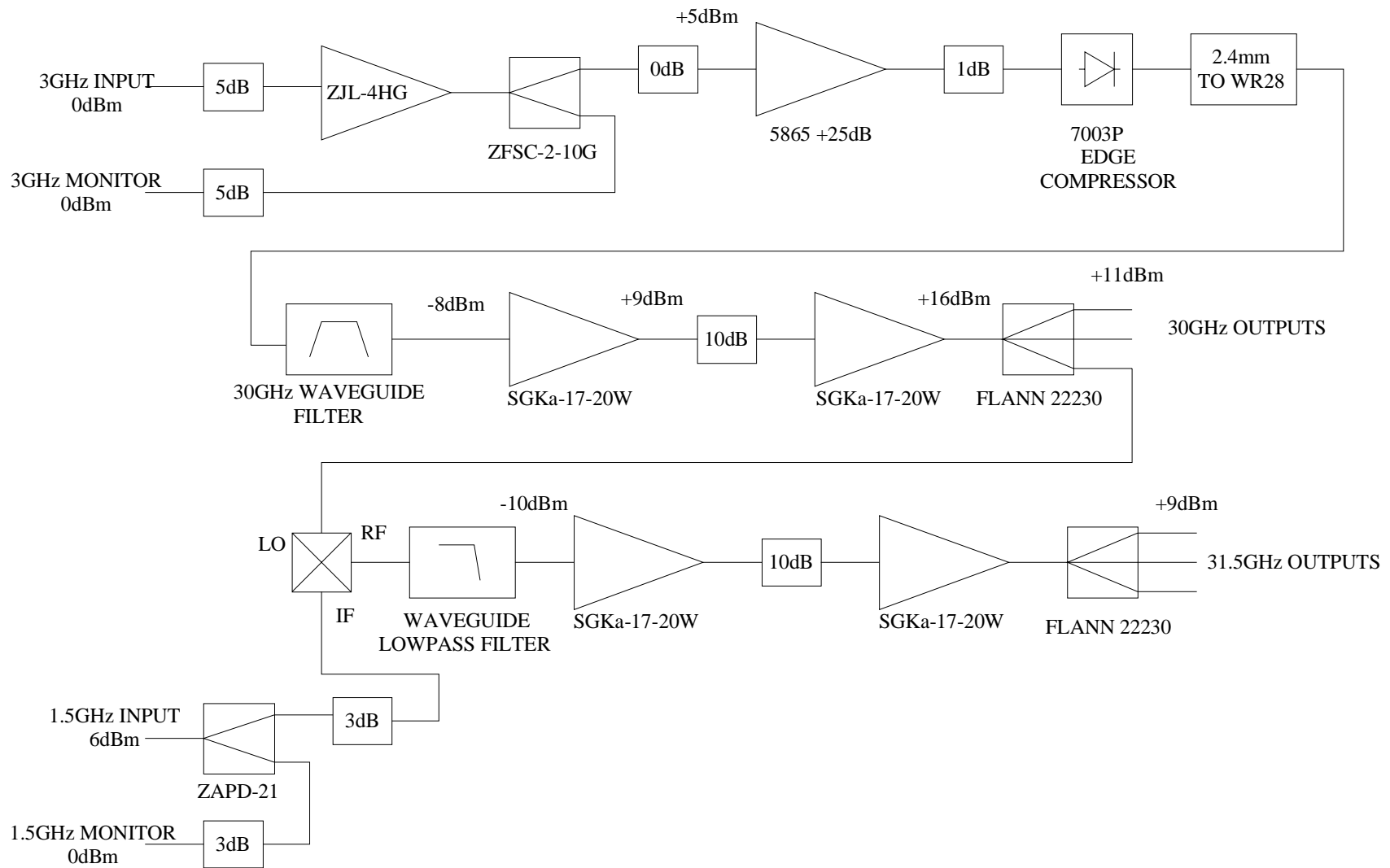

The 31.5GHz Generating Box

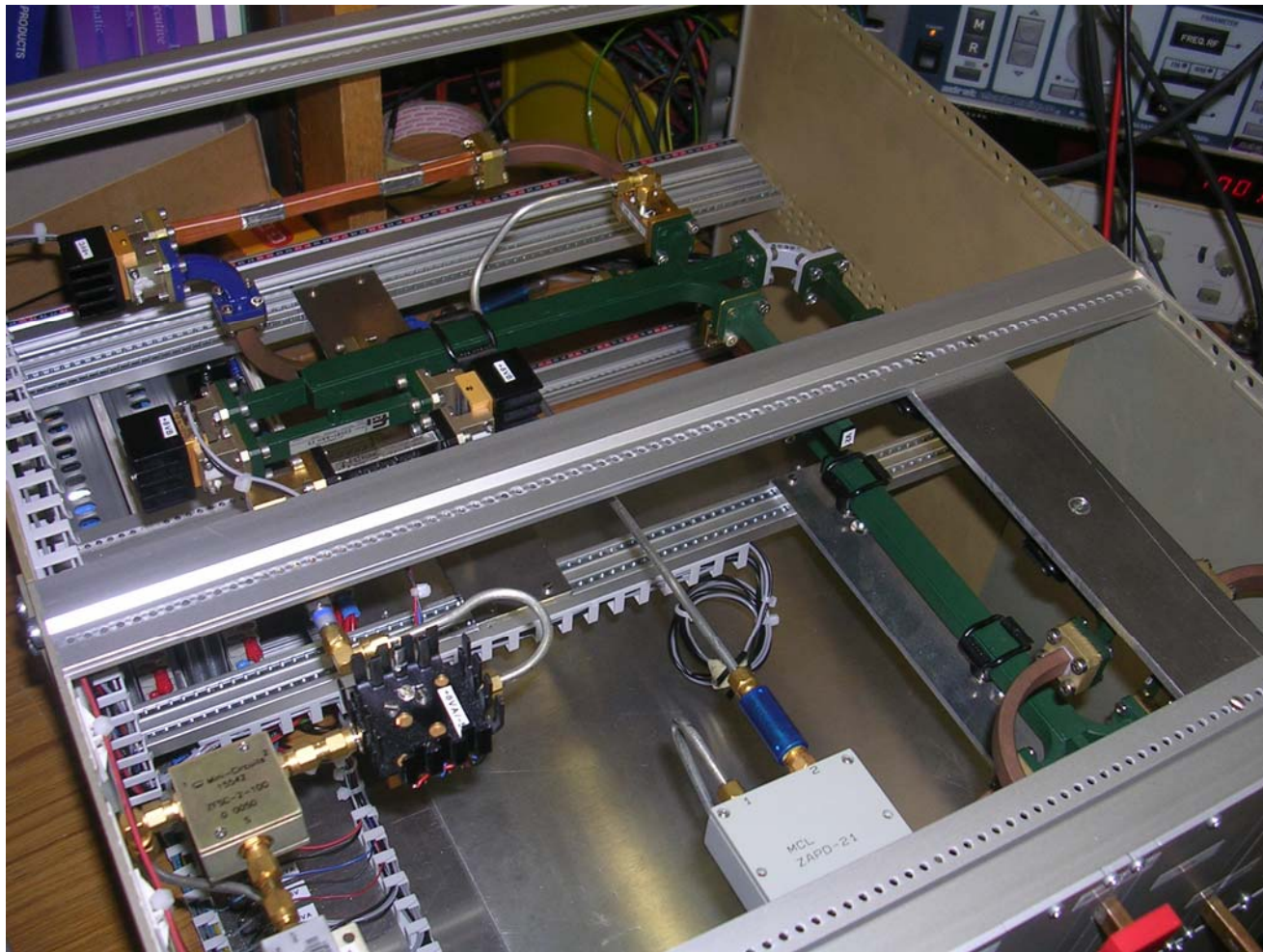

The IQ Demodulating Box

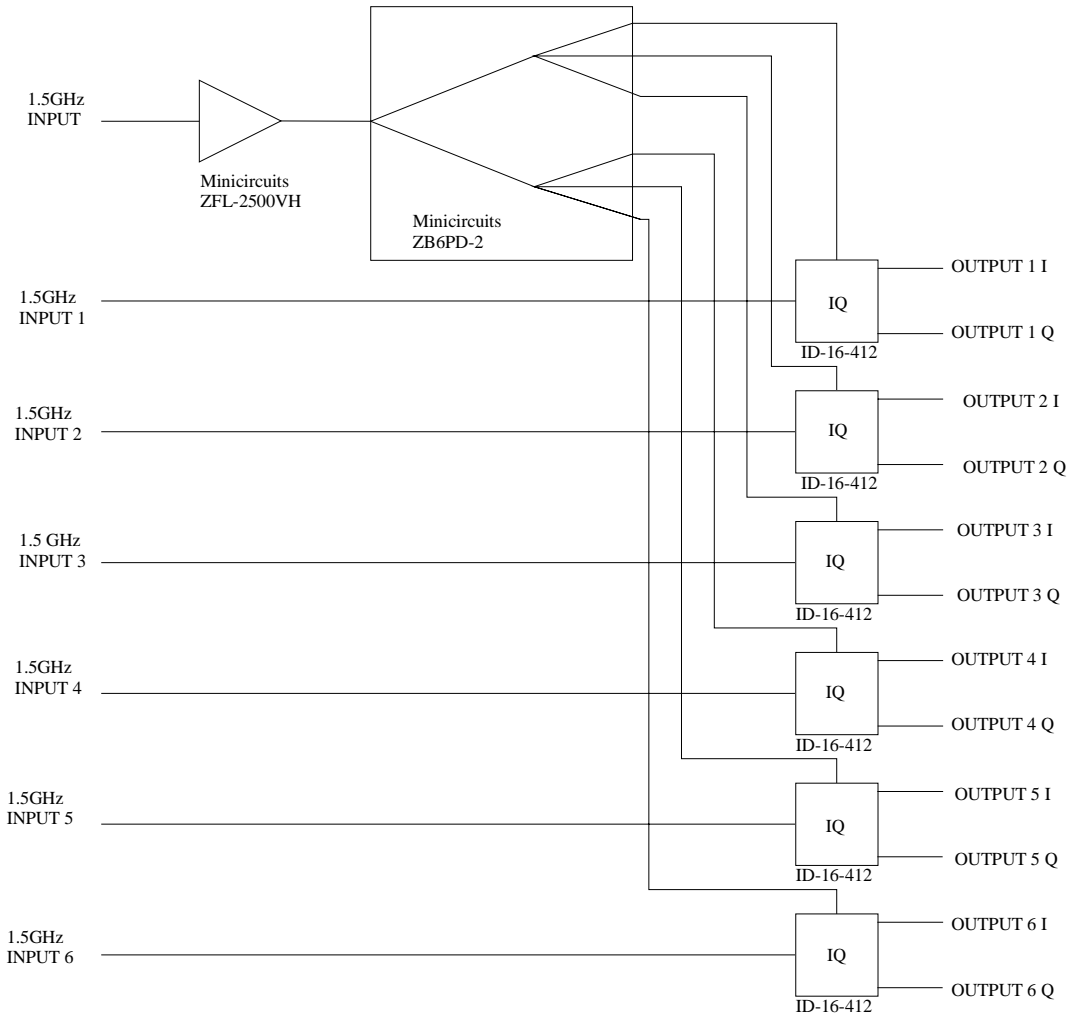

$$A(t) \cos(\omega t + \Phi(t))$$

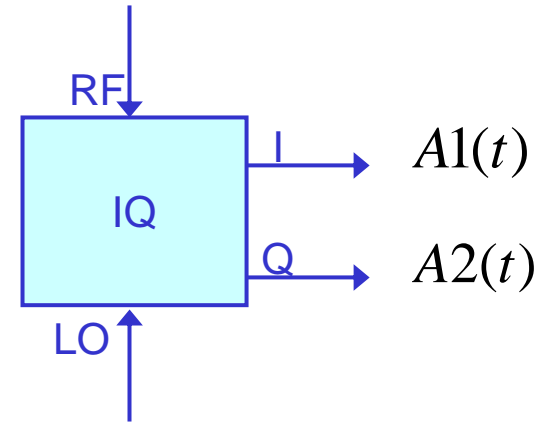

$$\cos(\omega t + \Phi(t))$$

$$A(t) = \sqrt{A1(t)^2 + A2(t)^2}$$

$$\Phi(t) = a \tan\left(\frac{A2(t)}{A1(t)}\right)$$

The IQ Demodulating Box



The IQ Demodulating Box: Testing

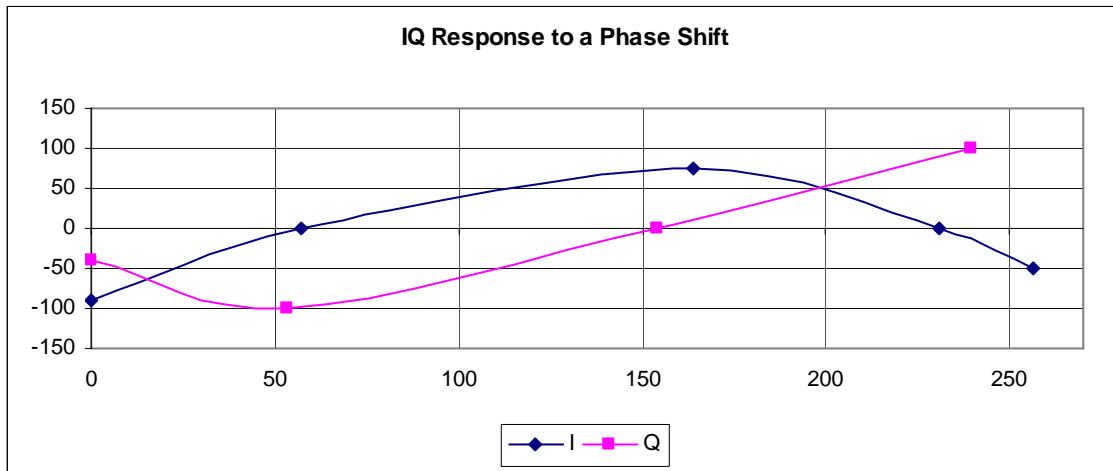
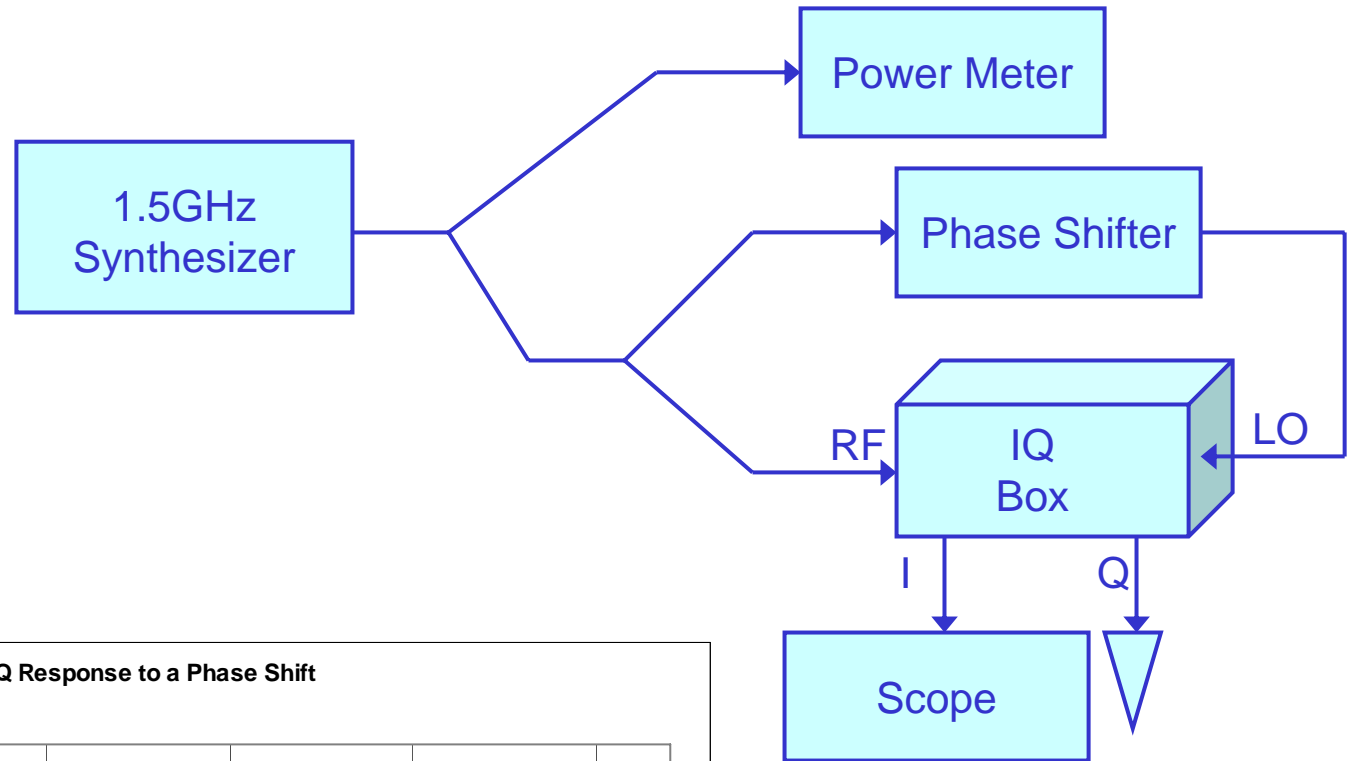

The Digitizer Cards



- 4 channels
- 1GHz bandwidth
- 1Gs/s sampling rate
- Acquisition memory 128-512 kpoints

Status

- What we already have: **HARDWARE**
 - 6 Programmable attenuators (tested and calibrated)
 - 1 Down mixing box and 1 IQ box (tested)
 - The 31.5GHz generating box (by Jonathan Sladen)
 - 2 Digitizer Cards (8 channels → 2 RF channels + 2BPM signals + FC)
- For the beginning of the run: **SOFTWARE**
 - Installation of the new electronics ready (installed, tested & calibrated)
 - C program for the automatic conditioning (Alexey Dubrovskiy)
 - Matlab & Java user interfaces (Alberto Rodriguez & Alexey Dubrovskiy)
 - Lab View attenuator controller and calibration updater (Raquel Fandos)
- For the middle of the run: **MORE HARDWARE**
 - 4 new digitizer cards
 - Components for another down mixing and IQ boxes
 - 6 more programmable attenuators

The New Electronics Scheme: Next Configuration

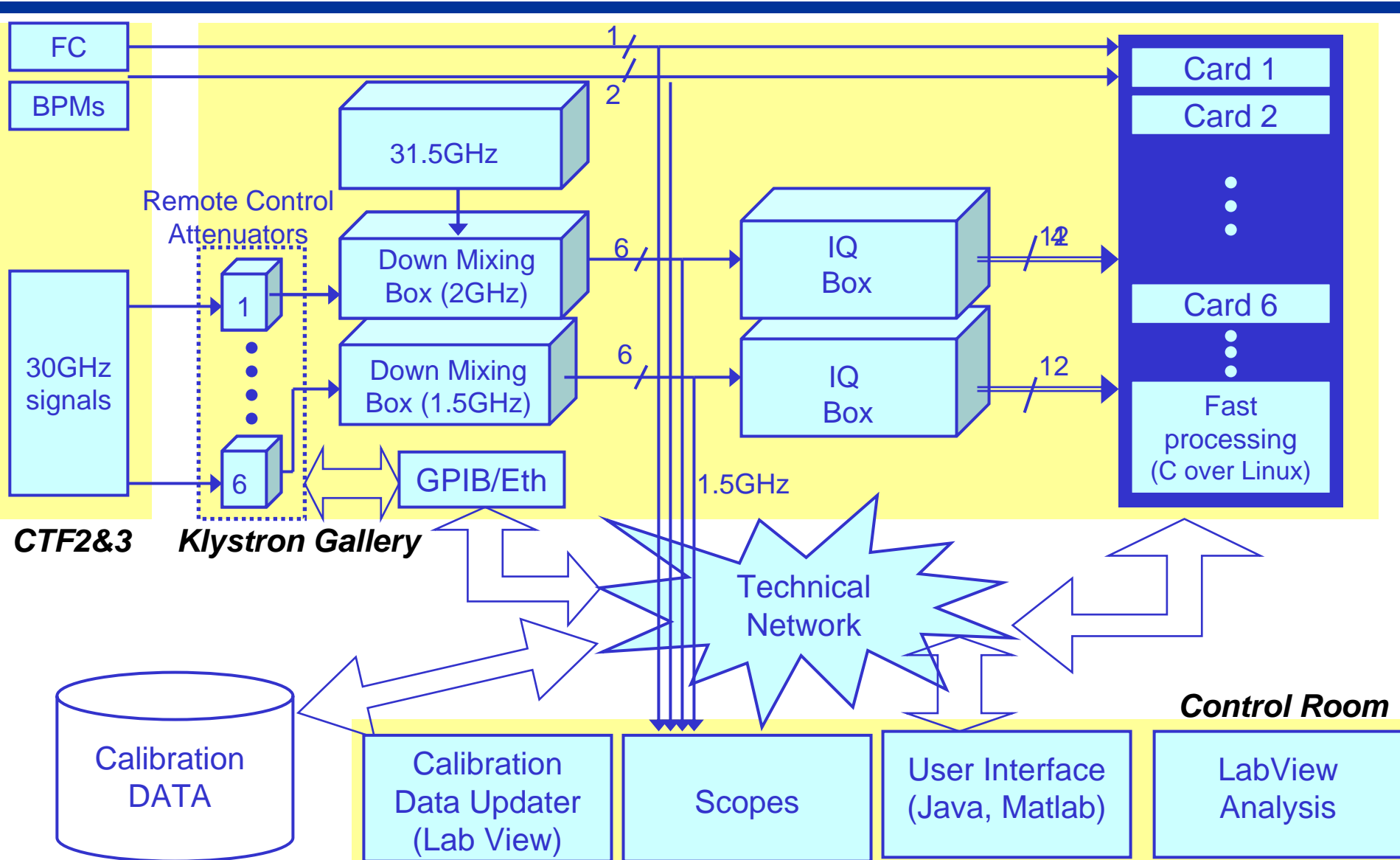

Thank you

Questions?